

DATE	SYM.	DESCRIPTION	DR	CK	REL

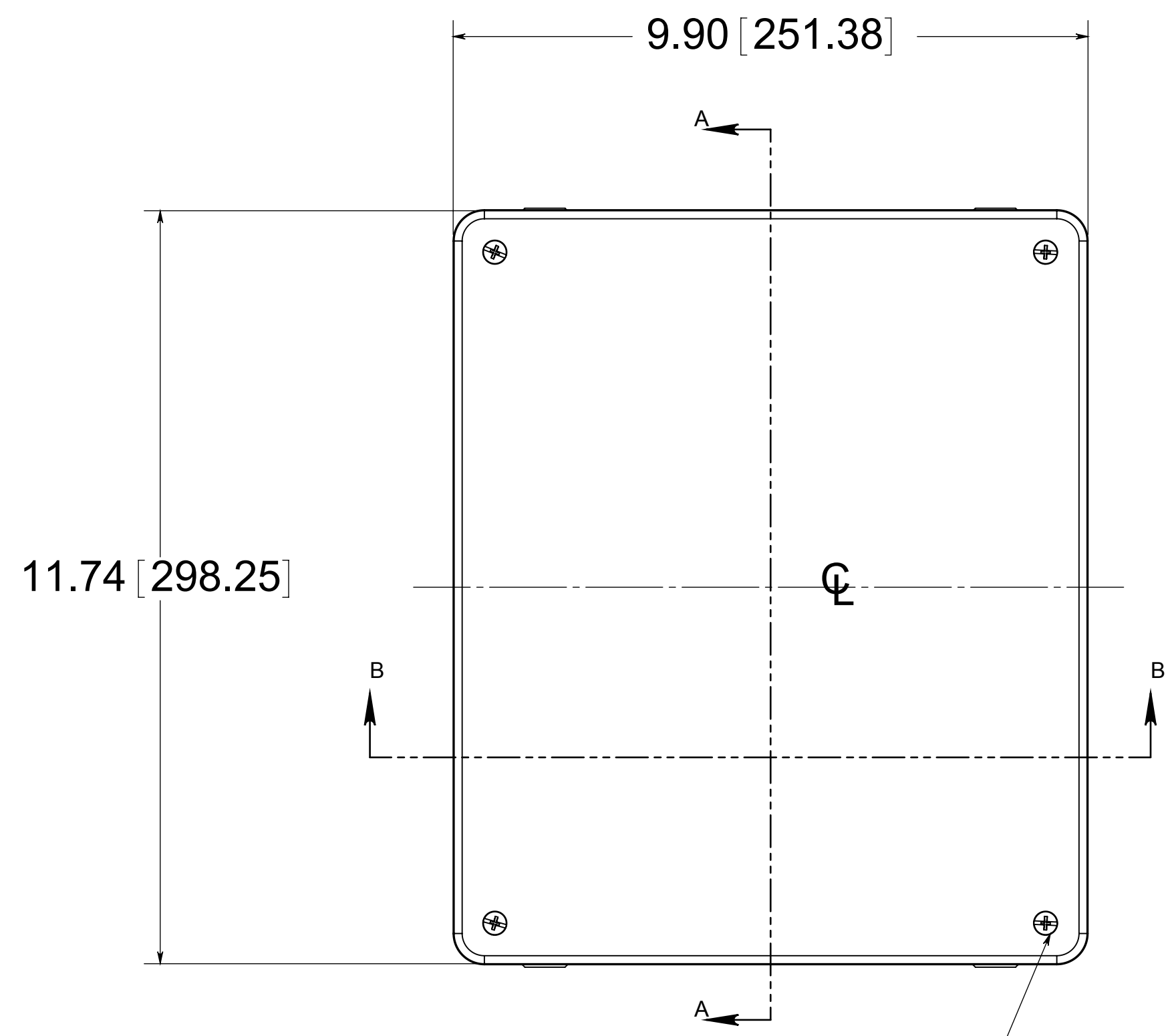

(4) EACH #10-32 BRASS INSERTS AND STAINLESS STEEL CAPTIVE COVER SCREWS WITH RETAINING O-RING

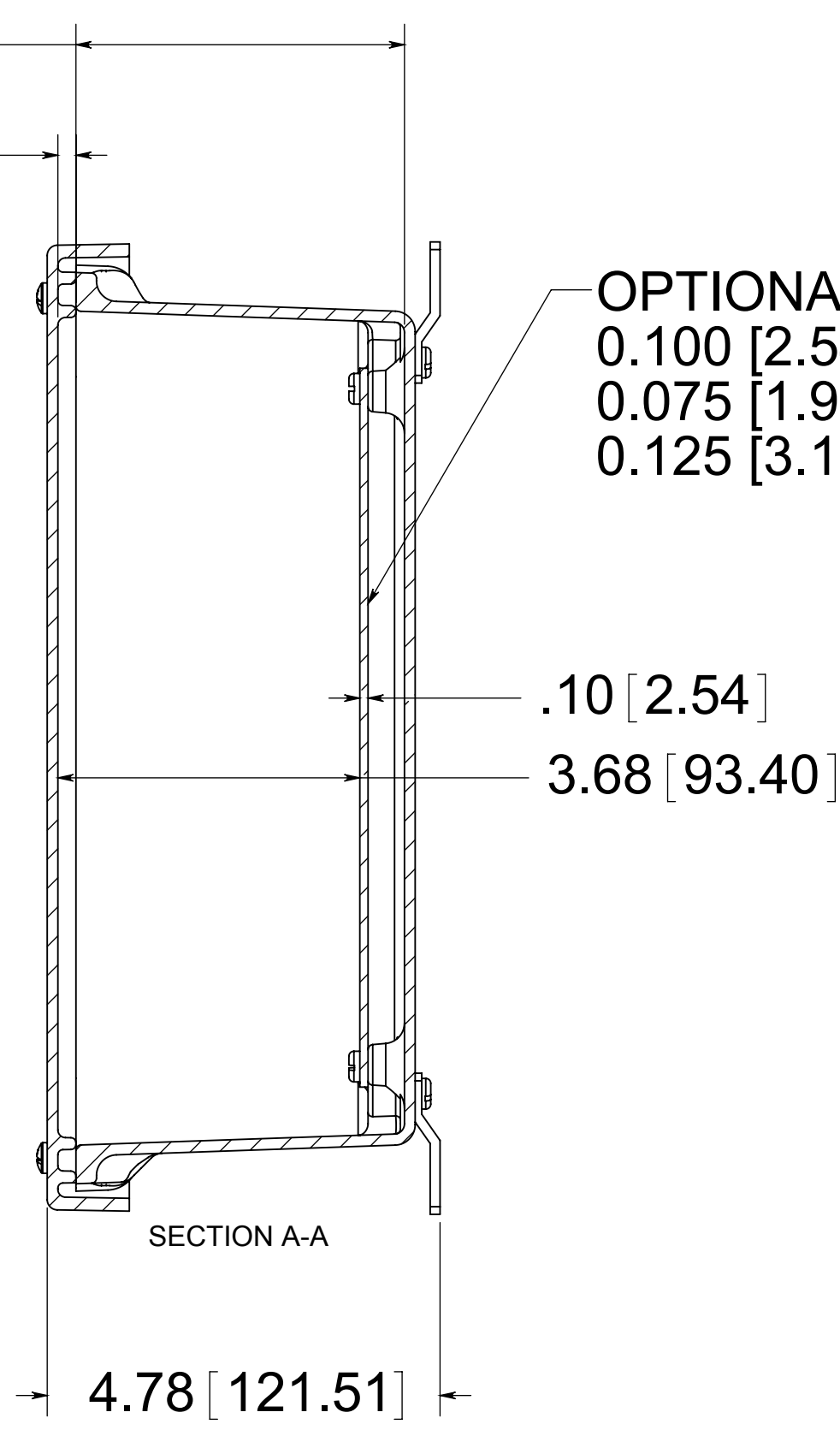

OPTIONAL BACK PANEL
 0.100 [2.54] TH'K- ALUMINUM
 0.075 [1.91] TH'K- WHITE STEEL & GALVANNEALED
 0.125 [3.18] TH'K- FIBERGLASS

(4) STAINLESS STEEL MOUNTING FEET
 (4) EACH #10-32 BRASS INSERTS, AND STAINLESS STEEL FEET SCREWS

(4) ϕ .34 [8.74]

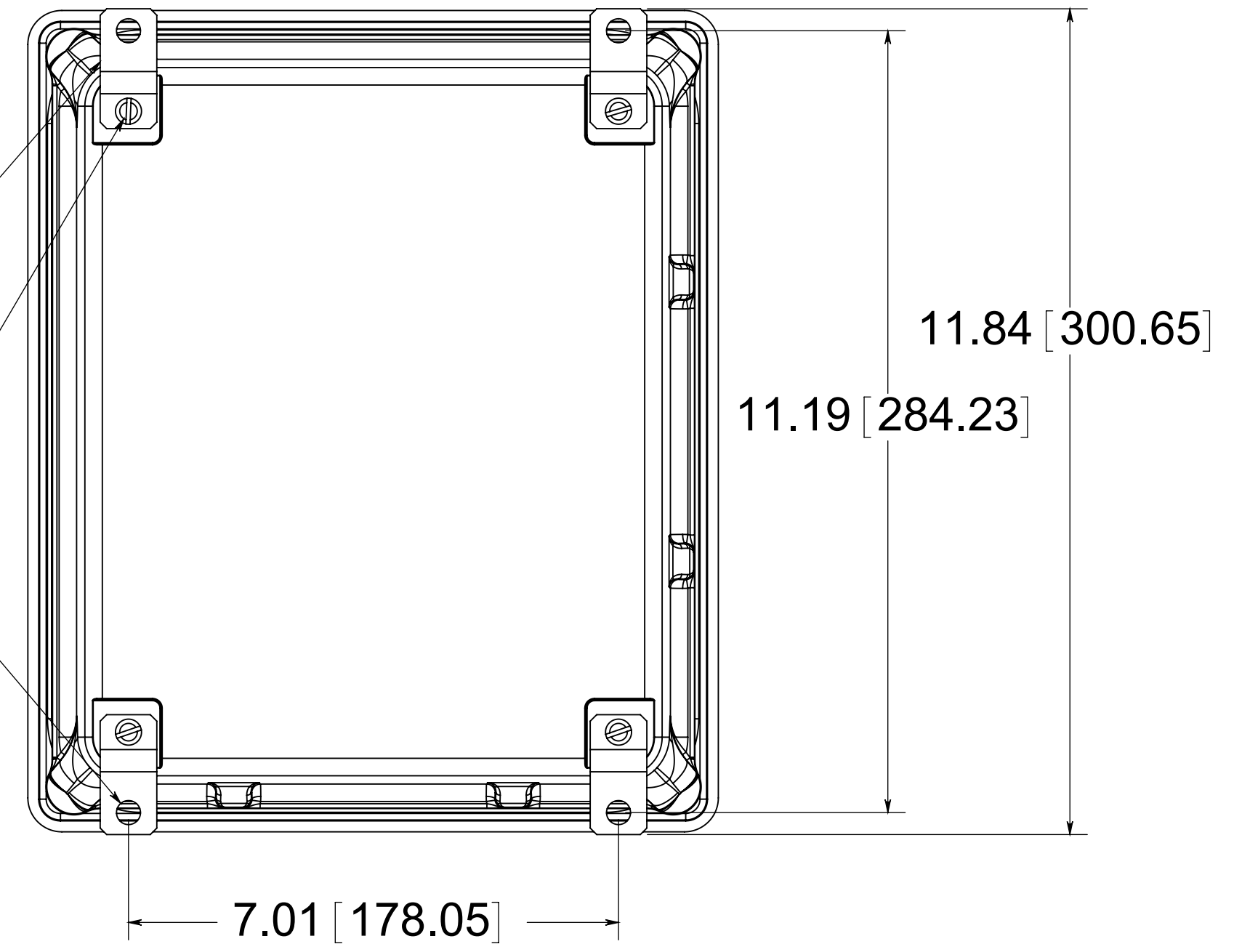

FRONT VIEW WITH COVER REMOVED AND BACK PANEL SHOWN

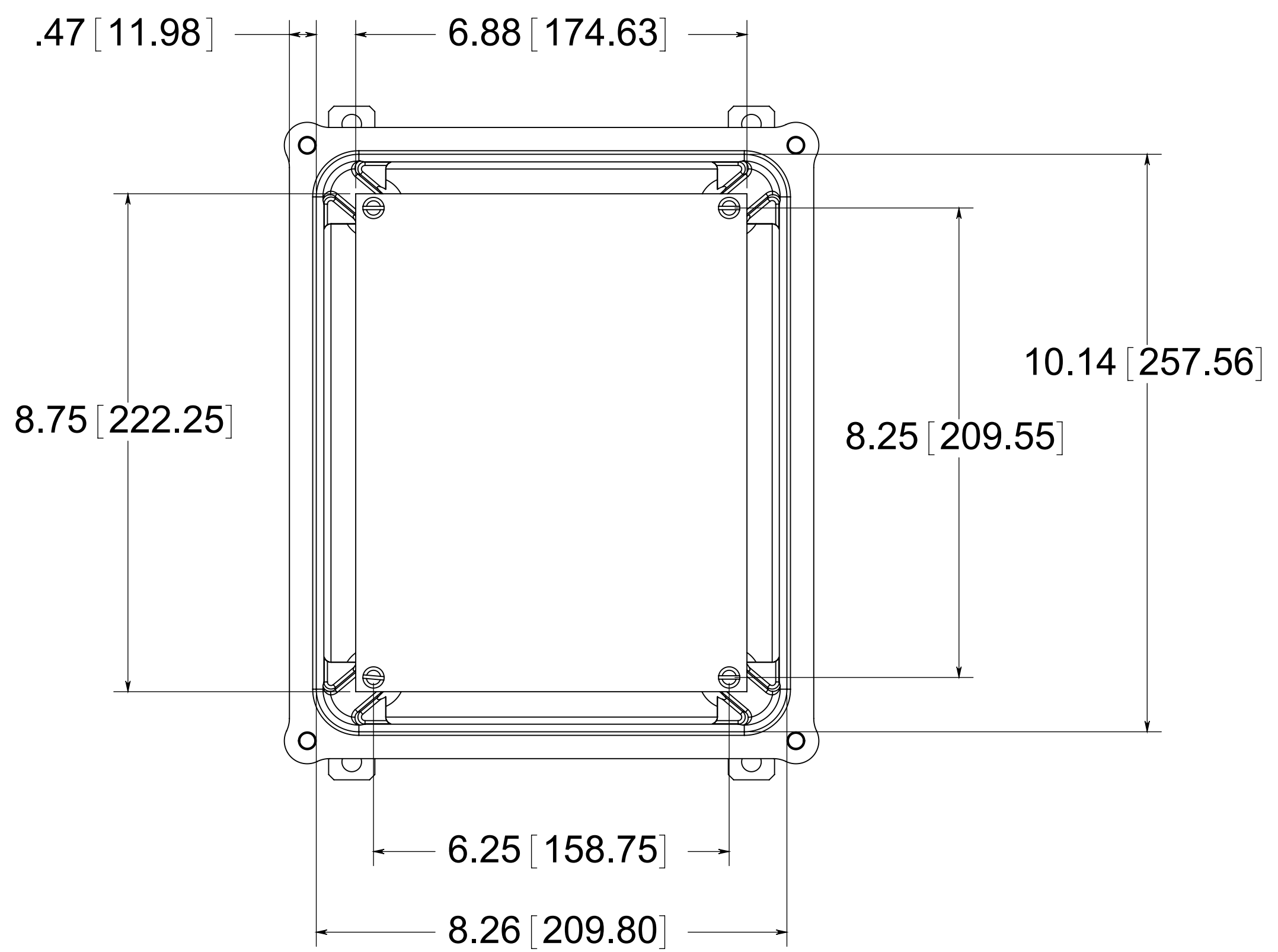

CLOSED CELL NEOPRENE GASKET

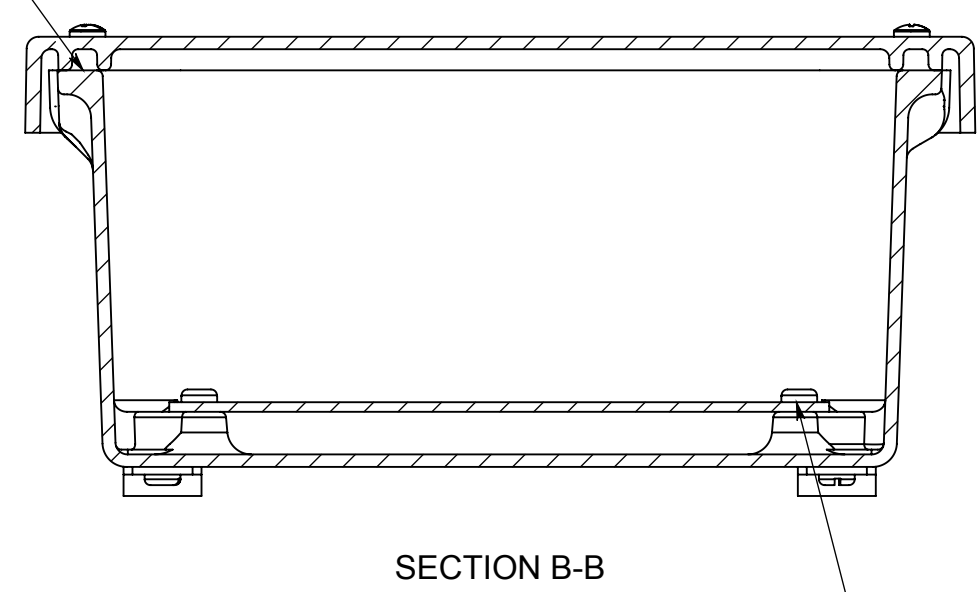

(4) EACH #10-32 BRASS INSERTS AND PLATED CARBON STEEL SCREWS

MATERIAL:
 BOX- COMPRESSION MOLDED FIBERGLASS REINFORCED POLYESTER
 COVER- COMPRESSION MOLDED FIBERGLASS REINFORCED POLYESTER
 WINDOWS- POLYCARBONATE

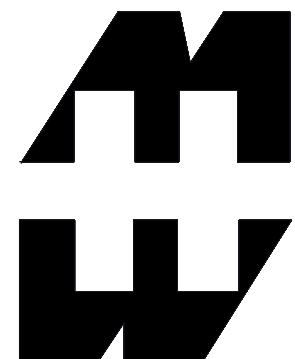

PART No. PJ1084
 for more information visit www.hammfg.com
 Data subject to change without notice
 Drawing Not to Scale